

Enterprise Turbo Speech

Background Speech-Assisted Transcription for
Dictaphone® Enterprise Speech System

Highly Productive Transcription for On-Premise, Enterprise-Wide Clinical Documentation

CHALLENGE:

Is there an easy way to reduce transcription costs and turnaround time without sacrificing high quality documentation?

SOLUTION:

Enterprise Turbo Speech increases transcription productivity by 25%–75% to lower transcription costs and improve turnaround time without compromising documentation quality.

Enterprise Turbo Speech is the background speech recognition component of the **Dictaphone® Enterprise Speech System** that enables highly productive speech-assisted transcription.

Dictaphone Enterprise Speech System is for hospitals, medical centers, and clinics that require an enterprise-wide, speech-enabled dictation/transcription system with full operational controls and system flexibility. System scalability, a wide-range of dictation options, and advanced workflows ensure a customized solution that meets evolving clinical documentation requirements.

Doesn't Impact Physician Workflow

Enterprise Turbo Speech minimizes technology adoption risks because clinicians do not have to change their dictation methods. Physicians can dictate with a variety of devices

Key Benefits

- Improves transcription productivity 25%-75%
- Reduces transcription costs up to 50%
- Reduces or eliminate outsourcing
- No impact on physicians' workflow
- Ensures widespread physician adoption
- Improves turnaround time
- Maximizes documentation cost savings

Key Features

- Dragon® Medical speech technology
- Smart ReWrite™ continuous learning
- Multiple language models
- Sophisticated shortcuts and templates
- Synchronized voice and text playback
- Acoustic adaptation
- Fluency meter
- Language model identification
- Auto punctuation
- Auto section headings
- Voice normals
- Customization client
- Magic keys
- Independent cursor
- Keyboard or foot pedal dictation playback

that best match clinical workflow and documentation needs. Dictation options include telephone, dictation stations, PC-based digital recorders and wireless PDAs.

Many physicians whose facilities adopt Enterprise Turbo Speech are unaware that it is in use. Physicians dictate as they normally do, while speech recognition technology translates their dictations into highly accurate, formatted draft documents for transcription. The speech technology constantly monitors transcription edits to documents and provides feedback to the speech engine for continuous accuracy and formatting improvements.

Physicians are not required to participate in any direct training to take advantage of this technology. The speech evaluation process is managed through Enterprise Turbo Speech and includes many automated features to ensure rapid speech recognition deployment with minimal administrator re-training. Physician speech evaluation and setup requires only 15 minutes of dictation.

Transcriptionists No Longer Type From Scratch

With Enterprise Turbo Speech, transcriptionists no longer need to type dictations from scratch. Instead, they review and edit highly accurate, formatted draft documents transcribed by speech recognition while listening to the dictations. Proprietary language models and custom post-processing capabilities optimize recognition accuracy for all medical specialties.

Smart ReWrite™: Intelligent Document Formatting

Converting a physician’s dictation to a final clinical document requires more than just typing. Transcriptionists typically must interpret and format dictation into documents, which meet their organization’s standards.

Smart ReWrite, a proprietary technology from Nuance Healthcare, learns the structure and style of each physician’s documents and automatically corrects grammar mistakes, handles rephrasing, customizes formatting and learns new medical terminology.

Smart ReWrite provides automated formatting features, which help properly structure and organize documents prior to transcription. These include:

- ▣ **Auto-punctuation**—applies proper punctuation to draft documents whether explicitly or implicitly stated within the dictation.
- ▣ **Auto-section headings**—applies the proper formatted section headings to each document worktype for each physician.

Smart ReWrite Example

Physician Dictates:

“physical exam ... vital signs ...temperature 98 point 7... blood 140 over 70... medications... tylenol 325 milligrams qd...”

Resulting Draft Documentation:

Physical examination
Vital signs: Temperature 98.7, blood pressure 140/70
Medications: Tylenol 325 mg daily

“We have seen a huge increase in productivity since going live with Enterprise Turbo Speech. I have eliminated all my outsourcing, which was approximately 40-50% of our work, in less than two months.”

—Tana Billman
 Coding/Transcription Supervisor, RHIA, MHA
 St. Vincent Healthcare
 Billings MT

“The increased productivity from Enterprise Turbo Speech allowed us to eliminate our outsourcing. Our transcription staff loves the new system.”

—Linda Haywood
 Director, Health Information Management
 Forrest General Hospital
 Hattiesburg MS



Smart ReWrite learns with use. As the technology processes more reports from a given physician, the accuracy and formatting improves, resulting in draft reports that closely approximate finished medical reports.

Additionally, the customization client allows administrators to manually incorporate specialized vocabulary and formatting.

Speech-Assisted Transcription “Turbo Charges” Productivity

Enterprise Turbo Speech leverages the automated dictation and documentation workflow functionality of the Dictaphone Enterprise Speech System to maximize technology investments. Enterprise Turbo Speech technology ramp-up and adoption is rapid to ensure healthcare facilities realize savings quickly. Most healthcare facilities realize dramatic productivity increases in less than two months from go-live, with 75%-95% of their transcription processed with speech.

Dictaphone Enterprise Speech System Workflows

- (A)** Dictaphone Enterprise Speech System captures and routes dictations.
- (B)** Enterprise Turbo Speech converts dictations into highly accurate and formatted draft reports.
- (C)** Transcriptionists review and edit draft reports.
- (D)** Physicians review and electronically sign reports.

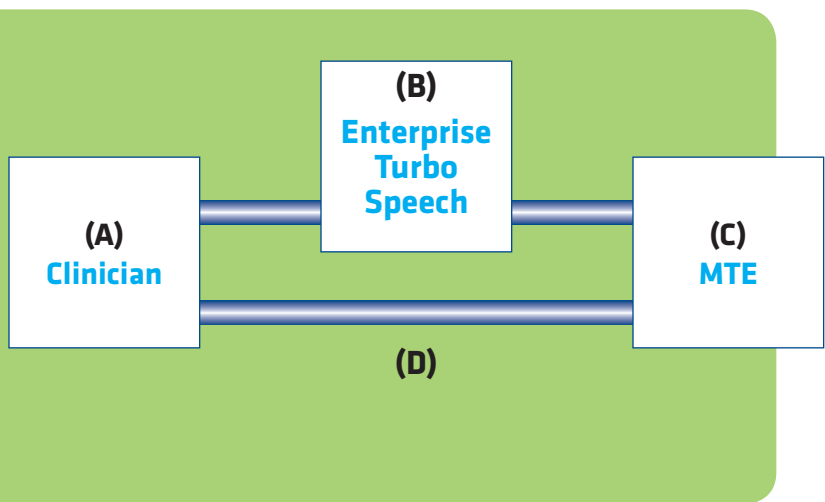

Nuance Healthcare Solutions

Dragon® Medical—A real-time speech recognition program that works with virtually any Windows®-based or Citrix® EHR system for efficient report completion, and easy navigation and adoption of the EHR.

Dictaphone® Enterprise Speech System— On-premise dictation/transcription platform with back-end and front-end speech recognition with full controls and advanced workflow flexibility.

eScription—On-demand platform for computer aided medical transcription, using background speech recognition to turn clinician dictation into formatted draft documents that medical transcriptionists—whether in-house or outsourced—can quickly review and edit, typically doubling productivity.

PowerScribe®—A web-based speech recognition solution that can help radiology departments significantly reduce report turnaround time and lower transcription costs by as much as 75%-100% a year.

RadCube™—A comprehensive, yet flexible, data warehouse for multidimensional business analysis and visualization.

RadPort™—A secure, web-based decision support application for appropriate diagnostic image order entry that satisfies pre-certification requirements.

RadWhere™—A data-driven, front-end speech recognition reporting application designed for multi-site workflow orchestration.

Veriphy™—A critical test results management solution that enhances patient care, increases physician productivity, improves risk management and automates compliance.



eScription

© 2008 KLAS Enterprises, LLC. All rights reserved.
 KLAS (www.healthcomputing.com) is a leading research organization which reports the performance of healthcare information technology (HIT) and services vendors.

About Nuance Healthcare

Nuance Healthcare is a division of Nuance Communications, the world's leading provider of speech and imaging solutions. Today, Nuance Healthcare provides the most comprehensive family of speech-driven clinical documentation solutions available anywhere. Our vision is to accelerate the adoption of EHR systems, helping providers maximize the return on their technology investments.

Let Us Be Your Partner

Let us help you achieve your vision of computer-based clinical documentation created at the point of care.

To learn more about how Nuance Healthcare can help you improve financial performance, raise the quality of care, and increase clinician satisfaction, please contact us at **888-350-4836** or visit www.nuance.com/healthcare.

© 2009 Nuance Communications, Inc. All rights reserved. Nuance, the Nuance logo, Dictaphone, RadWhere, RadCube, RadPort, Veriphy, PowerScribe, Smart ReWrite, and Dragon, are trademarks and/or registered trademarks of Nuance Communications, Inc., and/or its subsidiaries in the United States and/or other countries. All other trademarks are properties of their respective owners.